

Important Notes

This fingerprint machine is designed to work with the newly issued V3.X version Time & Attendance software only, which is completely compatible with the original V2.X version that has been popularly applied to all machines, the new one own stronger function, more convenient, and more human nature for user than the V2.X version

Acknowledgements

Thank you for purchasing our product. Before using this machine, please read this manual carefully.

Notice

Please Do not place the product in the place with strong light, because the strong light may significantly affect the fingerprint scanning, and thus cause the fingerprint verification fail. This product is designed for indoor installation, if it has to be installed it outdoor, please place the equipment in proper environment. You must beware of not exposing it to wet or harsh state, the product work temperature rang is 0-40°C. Do not use your machine exceeding this range, keep your equipment away from the heat source and radiator. For long time use it outdoor and the internal heat of the machine, will cause problem to the operation.

Please keep it away from violent collision, which would cause the internal components loosened or damaged. And the equipment is not a waterproof; Do not place this equipment in wet or damp.

Please use the equipment as the notice, you will get good effect and test speed.

Notice: Fingerprint Enrollment and Identification shall be taken after the installation the fingerprint identification machine



Installation



Enrollment



Identification



Enrollment

Installation

Identification

How to place the finger

Make sure the fingerprint image captured is of a core of presented finger, a fingerprint is point to locate within innermost recurring ridge of any give finger.

To obtain a higher success rate, enroll same finger 3 times in a slightly-adjusted angle, one to the center, one incline slightly to the left. The third incline slightly to the right. Please follow the place procedure; the success rate will increase dramatically.

The correct way is:

Place a finger flatware on the sensor surface

Place it to the center of the sensor surface

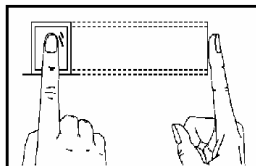

The wrong way is

Vertical

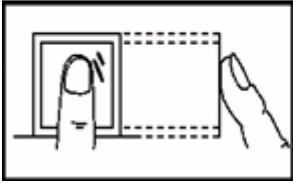

Offset

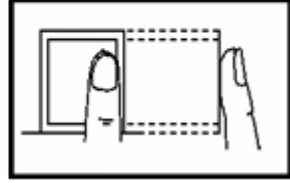

Inclined

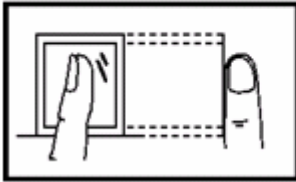

Lower

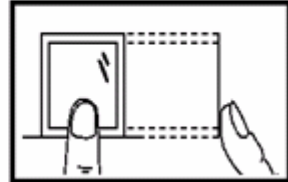

Notice: Please adopt the correct way to place the finger. Our Company is not responsible for any damages and troubles whatsoever arising out of from improper pressing manner.

About this Manual

All functions in this document are subjected to the actual product , as a result of the product is unceasing renewal, all attempts have been made to make the information in this document complete and accurate. Our company **is not responsible** for the actual product is consistent with this material, is not responsible for any direct or indirect damage or loss of business resulting from inaccuracies or omissions, the specifications in this document are subjected to change without notice

About 8" TFT iClock

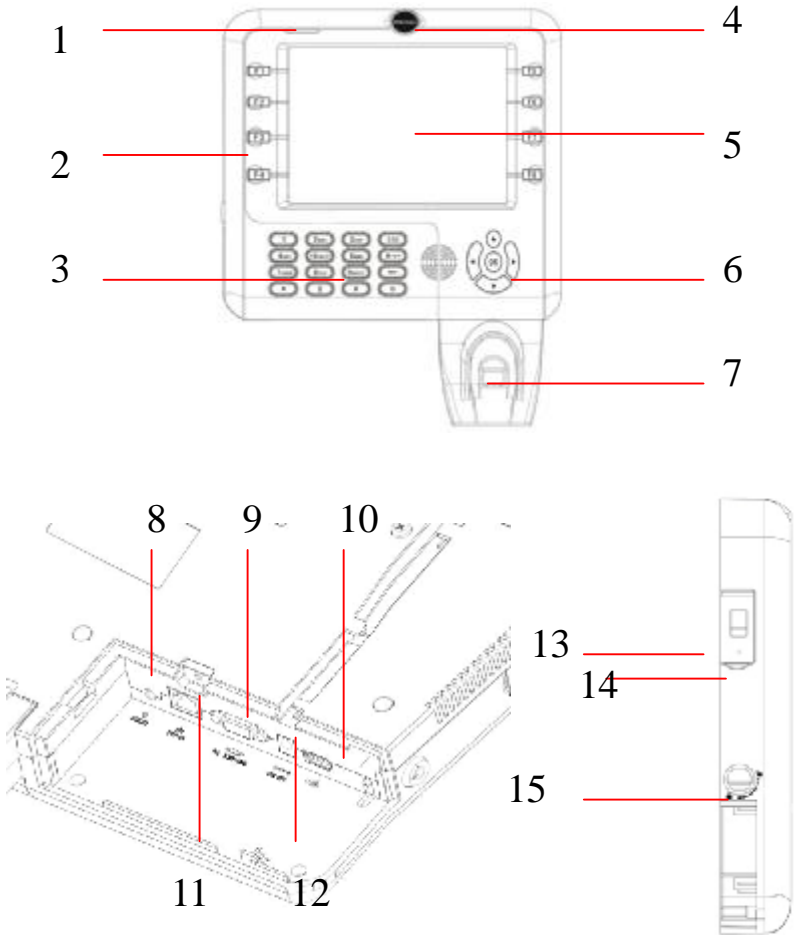

1 LED indicators: at normal working the green light blinking per one second, if the verification is positive, the LED will glow green for long -three seconds, If the authentication fails ,the LED glow red for long-three seconds.

2 Function keys: state key and functional shortcuts.

3 Small keyboards: to key in Chinese characters, letters, numbers, etc., and the menu operation.

4Camera: take a photo when user go on authorization

5.Touch Screen: display the operation result

6 Joystick key: locate various options by right, left, above, under position.

7 Fingerprint Sensor: match with the fingerprint.

8 Audio jacks: External speaker box.

9 RS232/485 port: RS232/485 communications between the equipment and the computer

10 USB port: for external USB devices (such as u disk, fingerprint sensor).

11 RJ45 port: for and computer network connections.

12 Power outlet: Access for power.

13 USB port: for external USB devices (such as flash disk, fingerprints sensor).

14 Reset key : when the machine is in halt, push this key with samll tools

13 Key hole: Lock the whencover of the Cable Box

Installation Steps

- 1) Mount the metal plate on walls in the appropriate place and fix it.
- 2) find the key along with the product. Open cover of the cable box
- 3) Connect the cable with machine, make sure that the wired machine align with the plate , then hang it on the plate and fix machine with screws below.
- 4) Arrange the machine's vertical edge so that they are in line with edge of the cover of the cable box, alignment, hold the machine bottom, and after in accordance with gently push the cover toward the vertical direction, shown as ②arrowhead.
- 5) Push the cover until it is parallel with the bottom of machine, and then push lightly the cover toward the right level until the cover completely meet with the machines.
- 6) Use the Key lock the cover

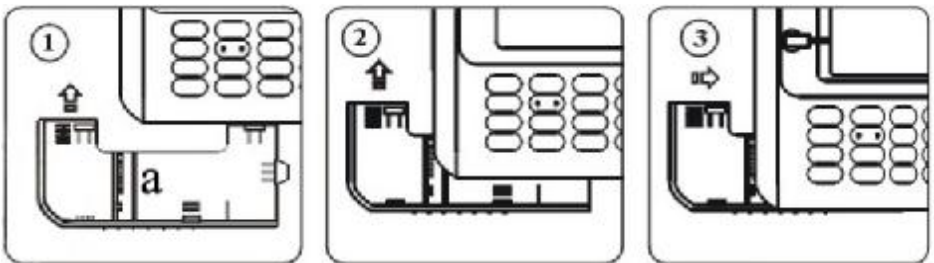

Recommendation step

Step 1: Place the fingerprint machine properly and power up machine.

Step 2: Enroll user, register fingerprint and password, and assign privilege to user.

Step 3: verify user by the registered fingerprint and password.

Step3: Configure the communication parameter; download the staff information to software using the U flash disk or one of three communications which is used to connect with the computer.

Step 5: Revise the staff's information in the staff maintenances item of software, connect the equipment with PC again and upload the staff information to the equipment. At this time when the fingerprint machine track staff's Time & Attendance log , his/her name will be display on the screen.

Step 6: Check the fingerprint machine time, and make sure whether it is correct, after completing setting up, then start to track employee's attendance.

Step7: At the end of the month the downloaded attendance log to software will be calculated.

The equipment is at the standby status.



Ready state is shown in photographs, users can upload images (see 7.4 upload custom photo), but also can shift the clock displayed on the screen intermediate (See 5.1 interface installed).

When the equipment in ready working mode, users press OK button or touch keys on the screen after the player launched flash player, the middle of the screen broadcast flash animation

After user verification completed by the fingerprint or the password the attendance log will be saved in machine general

About Play Flash

To play flash is available for this device, after loading the flash file into machines, the device is able to play flash in the ready state, so it can produce some publicity flash and upload it into the machine to play.



Ready work:

The ready work equipment as shown below:



After playing the flash , the player interface will automatically shut down , in the process if press any button to stop players and return to the ready working mode.

Touch Screen

The devices support touch screen. That is, if we conduct an operation without keyboard by pressing option to choose , it is only need to use the touch pen or fingers, such as touch the icon or menu , according to the location or menu the system will locate and input information, this can be user-friendly operation.

For example: now Users attempt to enter the menu for operation.

Instructions

There are two methods can be used,

The First: Pressing  into the menu.

The second: finger touch the icon regional of Menu on the screen

About Time &Attendance

When the equipment in ready work mode, users verification is positive by the fingerprint or password, whose attendance record will be tracked by the machines and the records will be saved.

How to choose the Attendance state

The equipment is in ready mode, press the function key of the equipment around both sides of the screen to shift attendance state and the state button corresponding state information is displayed on the screen, the current selected state glow in orange highlights.

After 8 seconds showing, press the "ESC" key the messages will disappear.



Use fingers touch the display area on screen lower right of the key corresponding state information can be displayed once again. (See definition of state 5.5 keyboard definitions)

Track Staff Attendance

When staff punch –in or out, who will be more concerned about the current perform time, and so after staff in attendance the equipment will show the current time on the screen by clocks .

Time & Track Attendance by Fingerprint

The attendance record will be unable to be saved to the machine until user verifies successfully with her/his the fingerprint or the password.

(2) 1: N fingerprint validation

Match the fingerprint which is created by user press finger on the

sensor face and all fingerprints data in fingerprint machine

Step1: Press the fingerprint sensor with finger in proper method.



Step2: The equipment prompts "Thanks", the validation is successful. If the user's photo has been registered, the photo will appear



The equipment prompt "please place finger again ", go back to repeat operation.



(1) 1: 1 fingerprint validation (AC.NO +fingerprint)

Match the fingerprint which place the fingerprint sensor face and entry the related number with keyboard, when user's fingerprint quality is too poor to be recognized, this way 1: 1 will be available.

Step 1: Verify personnel's AC.NO that keyboard entry in the initial interface.



Step 2: Place finger on the sensor window in proper way

Step3: The equipment prompt "enrolled number is wrong", Means the number does not exist



Step 4: The equipment prompt "Thanks", the validation is successful.



When the prompt “please try again?” appear.



In the equipment there are default two times to allow the staff to try, Times range is setted in 5.1 interface. After failing to verify two times, the user must return the step to operate again.

Track Time & Attendance by password

Step 1: Entry personel's AC.NO to be verified in the initial interface, press "OK" key

Step 2: If prompt the registered number is wrong, that means there is no the personnel's number; or the staff has not registered the password.



Step 3: the password interface appears, please input the password



Step 4: The equipment prompt "Thanks", the validation is successful.



The equipment prompts "the password is wrong", the interface will return to the password operation interface.



In the equipment there are default two times allowing the staffs to try, the number of times to be allowed to set in 5.1 interface. After failing to verify two times, the user must return the step to operate again

Track Time & Attendance by Card

Step 1: slight wave the cards near the induction area, after the equipment found the card, then remove the card from the equipment.

Step 2: When the equipment prompt “Thank you” appear, then the verification is completed”, if users’ photo has been registered.



Step 3: If the cards have not been registered yet, mention that card is unregistered



Note: the card induction area is 3cm -7cm above the small keyboard.

Connect with PC

This equipment will only track the attendance time record, but to get statistics result is unavailable till the software process the attendance record in the PC, therefore connecting machine with PC is necessary download attendance logs into Time & Attendance tracking software. There are some ports that support kinds of communications between machine and Time& Attendance tracking software:

Ethernet

(1) Via the Hub: With Straight Thru Cable (apply to connect network card and Hub) turns on, connect fingerprint machine to network.

(2) directly Connection: With T crossover cable (directly connect two Ethernet terminal) connect fingerprint machine to PC

Machine Option: Enters the menu - communication Option, please

set the following several items:

IP address: default IP is 192.168.1.201, which has to be resetted.

Subnet mask: default Subnet mask is 255.255.255.0, you may change it depending on actual application.

Gateway: the default gateway is 0.0.0.0, you may change it depending on actual application

Network speed: In network running speed, there are Automatic Adaptation, 10M and 100M, three options;

Connection password: in the Connection Setting. May change communication parameter, after setting, input the corresponding value on connection interface in the PC software.

RS232 way

Machine setting: Enter the menu - communication option, please set the following several items:

Baud rate: With the computer communication speed, the high speed communication is quick, it is better to use the RS232 communication; (115,200, 57,600).

RS232: Whether uses the RS232 communication, set this item as “Yes”

Communication password: in the “connection setting”. May change communication parameter, after setting, must input the corresponding value on connection interface in the PC

RS485 way

Machine Setting: Enter the Menu – Communication option, please set the following items:

Serial number: Assign a network ID. The serial number scope is 1

– 254.

Baud rate: the computer communication speed, the low speed communication is stable, we recommend that the RS485 communication Baud rate as 9,600 and 38,400.

If use RS485 to communicate, please set this item as “Yes”.

RS485: Communication password: in Connection Setting. After the password was setted, the corresponding value must be input on connection interface in PC.

Content

Important Notes	I
Acknowledgements	1
How to place the finger	2
1 Main Windows	1
2 User Management.....	3
2.2 View User	12
2.2.1 Search for users	13
2.2.2 Inquiries Attendance	14
2.2.3 Add New User	15
2.2.4 Edit User	16
2.2.5 Deletions users.....	17
3 System Setting.....	1
3.1 Systems parameters	1
3.2 Time and Date settings	5
3.3 Data managements.....	6
3.4 Upgrade firmware.....	8
3.5 Restore Setting.....	8
3.6 Automatically test.....	9
3.6.1 Test TFT screen	10
3.6.2Test pronunciations	10
3.6.3 Test keyboards	10
3.6.4 Test fingerprint Sensor	11
3.6.5 Real-time clocks	11
4 Communication setting.....	12
5 User profile.....	15
5.1 User Customize	15
5.2 Video Setting	18

5.3 Screen Calibration	19
5.5 The Definitions of Keyboards	21
5.5.1 State Key Definition	21
5.5.1 Using State Key	23
6 Inquiry Record.....	24
7 USB Flash Disk Management	27
7.1 Upload User data	28
7.2 Download User's Data.....	28
7.3 Upload the Customized Picture	29
7.4 Download Attendance Datum.....	30
7.5 Users Upload Photos	30
7.6 Download User's Photos	31
7.7 Upload Short Message.....	31
7.8 Download Short Message.....	31
7.9 Upload Flash.....	32
8 Information Release	33
8.1 Establish Short Message.....	34
8.2 View Staff Short Message	37
9. Systems Information.....	39
9.1 Equipment Information.....	39
9.2 Logs Capacity	39
Appendix 1	41
Getting Familiar with Keyboard.....	41
Appendix 2	43
T9 Input Method.....	43
Appendix 3	47
Quickly Inquire Staff Attendance Logs	47
Appendix 4	49
The Rule about the Advertising Pictures	49

Appendix 5 battery specifications and Notice 51

1 Main Windows

While device in readiness mode, Press  key to open main window, shown as following figure.



Instruction

On the Main menu interface you will find eight icons menu, namely: User Management, System Settings, Communications Settings, Customize Settings, Record Inquiries, U flash disk Management, Broadcast Information, Systems Information. In some menus, there are some submenus.

1) No Submenu Status

A: Press Function Key to enter the corresponding interface (F1 ~ F8).

B: Press ◀/▶ to move on, and press OK key to enter interface for operation.

2) Submenu Status

Press ▲ / ▼ key or press F1 ~ F8 submenu , the selected option will become in black grey colour, press OK key to enter interface for operation.

Press "ESC" key to exit from the menu.

2 User Management

For a fingerprint machine, user's basic information includes fingerprint, password and management privilege. When the company track staff Time & Attendance log, as a result of reassigning staff, the user information in the fingerprint machine also needs to correspondingly make the modification, therefore the fingerprint machine provide function to add, delete, search, change user and so on the operation.



2.1 Add new user

Firstly register the personnel's fingerprint or the password on the machine, whose time & attendance record will be tracked.

Enter the interface to add new user:

User Registration

User Registration:
 (1) Name: register Name (press F9 key to turn on input method, press ESC to turn off input method); Register new fingerprint, backup fingerprint (a register could backup maximum 10 fingerprints); password: Register Administrator privileges (administrator, ordinary user).

ID No:

Name:

PP:

PWD: PP Auth:

AUTH:

Card:

Pic:

ZKSoftware
 Technical Support: 800-858-8700

AC.No: Staff attendance number.

Name: use T 9 input method to key in user's name.

Fingerprint: Registered staff's fingerprint, to register ten fingerprints is available

the fingerprint may be used to check attendance by the staff whose fingerprint has been registered.

Registration password: The registration user's password, the effective figure of password is 1 ~ 8.

The registered password staff is possible to use the password to check attendance.

Enroll card: registered users passwords.

Enroll Photos: register user's Photos.

Registered user's photographs will be displayed in attendance performance.

Privilege: Users are people whose identity must be authenticated before enter a menu. The ordinary consumer can track attendance by the fingerprint or the password only; the manager already may equally carry on the daily checking attendance with the ordinary consumer, but may enter the menu to operate each option.

Note: When there is no appointed the manager, any person all may enter the menu operation; after appointed the manager, be unable to enter the menu until the manager status is confirm, after the success can enter the menu.

Example: the flow to add user as follows:

Input AC.NO

- 1) The equipment is assigned AC.NO by default.
- 2) Press the "←" key to delete the default assigned AC.NO, when entry AC.NO with the keyboard, if occur error. May press "←" to delete it and input AC.NO again. Directly press "OK" key or scroll the ▲/▼ key, and locate cursor on the "Enroll fingerprint" button to press the OK key again, go on the fingerprint registration.

Registration fingerprint

Enter the name

Press the * key to open T9 input method, entry the staff 's name,

with T9 input method input by the ESC from the completion of T9 input method.

Directly press the "OK" button or scroll▲ / ▼ cursor keys will be located in the "Registration fingerprint" button, then "OK" button, enter the fingerprint registration.

Enroll fingerprint

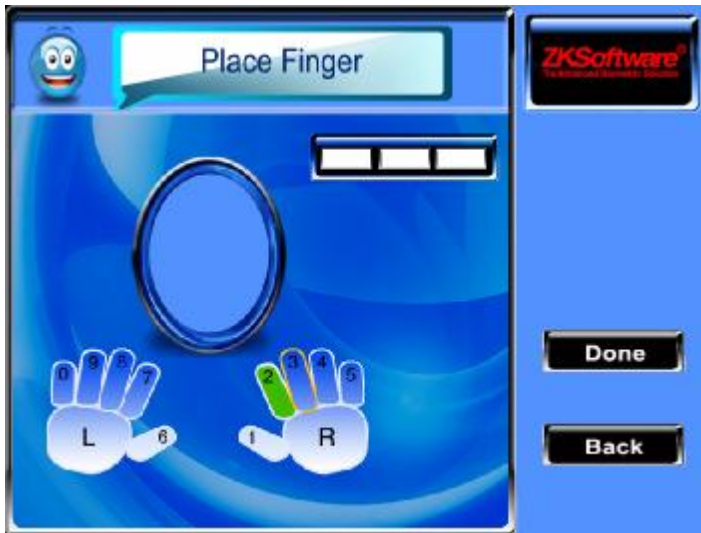

Note: 1) the fingers is shown as yellow frame that present the current selected finger.

2) The finger is shown as green that the finger has been registered, if the finger has been registered, the fingerprints will be re-registered and covered with the previous fingerprints.

3) Select the registered fingers, press keys to delete the fingerprint that is available.

4) Figure fingerprints registered in the default order of 2,3,4,5,0,9,8,7,6,1.

press key with the digital keyboard or scroll ▲/▼/◀▶ button, or touch the fingers which will be registered fingers. Follow the equipment prompt place the finger, you must continuously press the same finger 3 times in the correct method until the registration successful prompt appear

After registering fingerprint successfully, if need to continually register another fingerprints to press finger, directly after the completion of registration by (F7), "ESC" (F8) to return to the previous interface, The equipment will prompt the current number of registered fingerprint.

Scroll▲ / ▼key, the cursor will be located in the "Registration password" button, and Press "OK" to enter password registration.

Register Password

Following the equipment prompt, input the password , then press OK key and input password once again , only it is allowed to input 1 ~ 8 the effective figure for the password . After the input to save completed press  (F7) , if does not save it, press "ESC" (F8) .



After saving it, the icon  will display on the screen, which mean the password has already set in the device.

Enroll cards ★

Scroll ▲ / ▼ keys to locate the cursor on “enroll card” button, and press "OK" to enter the registration card .



Slight wave the card near the induction area, after the equipment found the card number, then remove the card from the equipment, after equipment prompt that the "Enroll successfully" the card number will be save up, or may press "Done" button to return to register interface.

After enrolling the card, the 🌟 icon will display equipment screen that means the cards is registered card, the employees can punch card to track whose attendance.

Registration photos ★

scroll ▲ / ▼keys, the cursor will be located in the "Registration Photos" button, and press "OK" to enter the video interface, to configure photo capture function is available .



After entering a snapshot mode of the equipment interface , scroll ▲ / ▼ key to switch options input box with the small keyboard, and input appropriate number keys to adjust the value of the camera filming effect, after appropriate adjustment press  (F7) or "OK" that is, photos can be captured, after the completion of the snapshot capture and save pictures, and the photograph will be shown for two seconds, re-entering the snapshot mode. If you are not satisfied with the pictures taken, press the "return" button. Continually capture photo again until you are satisfied.

View

Scroll ▲ / ▼ keys the cursor will be located in the "Registration Photos" button, and press "OK" here to view these registered pictures.



Press any one button or touch the region of images on the screen, can exit from photo browser .

Privilege setting

Scroll the▲/▼ key, and locate cursor on the "Privilege" option box, Scroll ◀/▶ key to choose privilege.

Save/exit user registration

To confirm the registration information is correct, after getting confirmation, save it.

The way for saving:

1) Press "F7" (F7) the key ,the prompt "Save successfully! Continues to input?" on the equipment, press "OK" the key to save it, if you Do not want saving, Press "ESC"



2) press "ESC" to exit. If the prompt "the data has been changed, Are you sure to save it?" appear on equipment, want continuing to press "OK", if you abandon this operation, press "ESC" key to return the previous menu.

2.2 View User

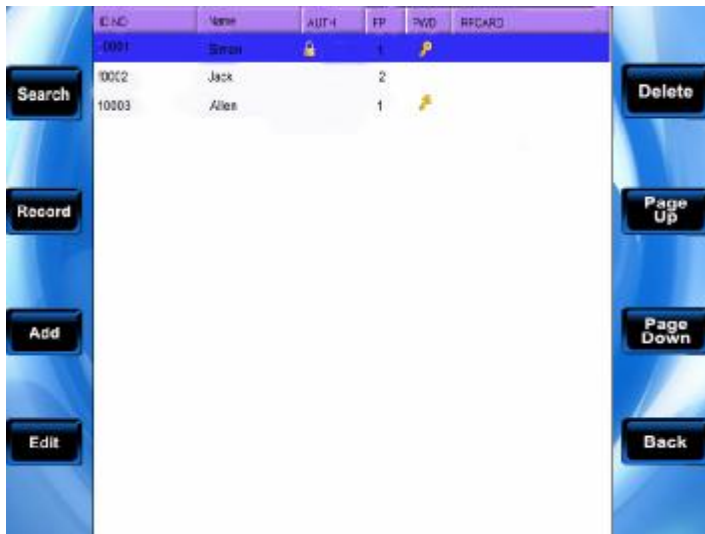
By means of the user view you can view all users' information in the current equipment is available, which include username, the number of fingerprint, whether the password is registered, and user's attendance logs. You are allowed to edit or delete some user



EAC	Name	AUTH	FP	PWD	RECORD
10001	Simon	🔒	1	🔑	
10002	Jack		2		
10003	Allen		1	🔑	

Note: 1) Shown as above figure, the icon  express that this staff is a manager, the icon  express that the password has already been registered.

2) The RF card No. will be displayed on the Card No. Rank

Scroll ▲/▼ key , the blue cursor locate at the line that want to be operate, press the function key where around the screen both side to do operation, Example , press F1 key to search user.

2.2.1 Search for users

When there are lot of registered user in the device, in order to provide the manager with convenient rapidly to find a staff, the equipment come with "AC.NO" "Name" to retrieve the staff.

Press the F1 key in the user browser interface, the operation menu appear:

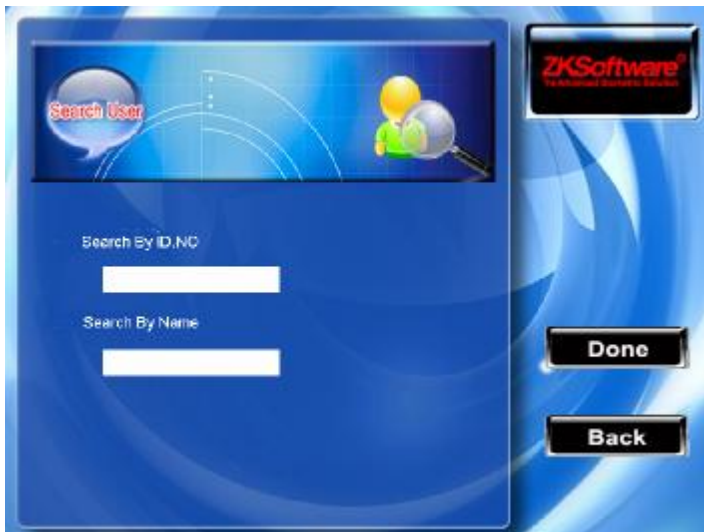

Input staff's AC.NO that you search for, press the "OK" key to

search, after searching successfully, the blue cursor will automatically locate on this staff name, if this staff you search does not exist in the device, the prompt "the non- registration data" will appear.

2.2.2 Inquiries Attendance

When the manager examine staff's registration information and fingerprint so on, meanwhile may track the staff's attendance record in the same month.

Press the F2 key in the user management interface, the operation menu appears, choose "Attendance inquires" item, may track the staff's that you choose the attendance record in the same month:

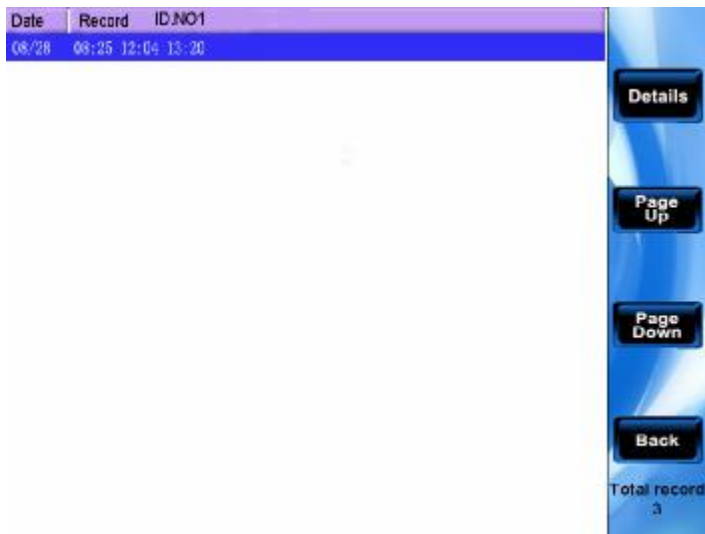

Scroll ▲/▼ key to browse the attendance log line by line.

Press F6/F7key to browse the attendance log page by page.

Press“ESC”/F8 return the user browser interface

Press OK/↵/F5 key to inquire the detailed situation.

ID NO	Name	Atlogs	Verifed	State
1	Simon	08/28 08:25	FP	Check-in
1	Simon	08/28 12:04	FP	Check-in
1	Simon	08/28 13:20	FP	CHeck-In
1	Simon	08/28 18:12	Pwd	Check-out



After the examination completed, press "ESC" (F8)key to return to the user management interface.

2.2.3 Add New User

There is an option that is easily operator to add user in the here, the function is some with 2.1 introduce. Press F3 to enter

2.2.4 Edit User

Makes the revision for user's information which have been saved in the machine, for example, if the registered fingerprint is invalid , renew the fingerprint or register the password, just enter the " edition user" available.

Press the "**M/←**" /OK /F4 key to display the user's information which has been registered:



The AC.NO is not allowed to revise again, other operations is similar with to add the user. Register the fingerprint again, if there is not the password or need to revise the password, then directly click on "Chg Pwd", the privilege also is allowed to revise.

Save edition/Exit edition

- 1) Press "M/←" the key to save editing result and return to the user management interface.
- 2) press the "ESC" key , prompt "the data have been changed, are you sure to save it" display on the equipment press OK, press " ESC" key to abandon operation.

2.2.5 Deletions users

The option "deletion user" is to delete staff's partial information or all information from the equipment, which apply to the following situation:

- 1) The staff's fingerprint or the password is invalid or Do not user any more.
- 2) After the staff lay off, administrator deletes her/his record from the equipment.

In the user management interface, scroll ▲/▼ key or search user to locate the blue color cursor at the staff that needs to edit, press the F5 key. The operation menu appears, your choice is "deletion user".

Deletion user



If there is not user's fingerprint or the password in the device, then his /her corresponding typeface is a blue color, be unable to operate it, scroll the ▲/▼ key to locate the cursor at the option which need to operate. Press the "OK" key the dialog box which asks you give confirmation will pop-up whether delete this item, after confirmation, the equipment should create the corresponding prompt, press "ESC" (F8) key to return to the user management page.

3 System Setting

To set up system parameter, make the equipment at the function, display with the perfect exhibition, pursue user's satisfactions.



3.1 Systems parameters

1: 1 matching threshold: When use ID+ fingerprint to recognize. Threshold a predefined number , often controlled by a biometric system administrator , which establishes the degree of correlation necessary for a comparison to be deemed a match .if the score resulting from template comparison exceed the threshold , the templates are a “match” (though the template them selves are not identical



1: N matching threshold: the degree of correlation matches with the registration template.



Recommend matching threshold setting: e. (effect value is 1 ~ 60 minutes)



Suggested Threshold Settings

FRR	FAR	One-to-many	One-to-one
High	Low	45	25
Middle	Middle	35	15
Low	High	25	10

Time format: Set up the time format in the fingerprint initial interface.

Scroll   key to choose form, the fingerprint machine supports 10 kinds of dates forms, YY-MM-DD, YY/MM/DD, YY.MM.DD, MM-DD-YY, MM/DD/YY, MM.DD.YY, DD-MM-YY, DD/MM/YY, DD.MM.YY, YYYYMMDD, and other date form of your choice

Keyboard voice: Scroll the   key to determine the whether send a sound when you press key , if set the option as "Yes" ,when press key the machine will utter, if set the option as ("No") you press key the machine doesn't utter.

Voice (Adjvo): Through the   / key configure the voice prompt, the equipment can produces the corresponding voice Prompt when the operation.

Volume: Adjust volume. Scroll   key to adjust volume as your

favor

Alarm attendance log(Alm Attlog), When the remainder log capacity reached set numerical value, it will automatically sound warning that logs will be full (virtual value is 1-99).

Recheck Minute: set it within the scope (unit: minute). Someone attendance has been recorded, then the second record will not display (virtual value is 66).

Fingerprint sensitivity: adjust the fingerprint sensors, the fingerprint sensor are too sensitivity, lower the value; When the first fingerprint sensors is too slow, increase the value of. (Scope 1 ~ 10)

Instruction



Scroll the ▲/▼ key to shifts the cursor on the item which you need set. If the item is inputting box, configure the value with the numeric keyboard input; If the item is rolls the frame, Scroll the ◀/▶ key to choose the value you need, after the setting finished, please directly press OK or  (F7) key to save this item and return to preceding interface, press the ESC (F8) key to give up operation and return to interface.

3.2 Time and Date settings

It is necessary to set the accurate date and time for each of equipments. To obtain guarantee for tracking the accurate attendance result.

Enter option to set the time and date :

Instruction



Scroll the ◀/▶ key to switch option input box, Scroll▲/▼key to shifts the cursor input box . set up the value with the numeric keyboard input After you set up completed, please press M/\leftarrow / “OK” (F7) to save this configuration, press the ESC (F8) key to abandon operation and return to the up page

3.3 Data managements

Delete attendance record (Clear Attlog): Deletes all attendance record.

Delete the complete datum (Clear All): Delete all registrations personnel information, the fingerprint and the attendance record.

Clear Admin Privilege: Change the Administer privilege into ordinary users' option:

Caution: Unable to restore any file you delete, please careful

Instruction



Scroll the▲/▼ key to shift the cursor on the button which you

will operate. press OK to start operation, when the prompt “ Are you sure to continue the current this operation?” appear on the equipment, press OK key again , be sure that the data will be deleted, if after you delete the data, the data will be unable to restore. Press ESC (F8) key to exit and return to up aged.

Remove publicity Photo: remove publicity pictures when equipment cycle show in ready working interface. (How to upload pictures, please See 7.4 upload custom publicity Photo)

Instruction



Scroll the “F3/F4” key to preview the publicity picture which has already saved in the equipment, if you want to delete this picture then press F6 key to delete it, after the prompt to delete successfully appear on the equipment , after deleted completed

automatically jumps to the next picture. If you want to delete all public picture in the equipment, Press  (F7) button. Press the ESC (F8) key to return to the data management interface.

3.4 Upgrade firmware

If want to upgrade the firmware of machine, may use USB flash disk to achieve.

Caution: to protect your normal use, we need to restriction that forbid anyone upgrade the firmware random, except with the help of the dealer upgrading the firmware. Inaccuracy upgrade would trouble the machine, that possibly affect the daily use.

Instruction

Plug the USB flash disk with Upgrade file into slot of equipment, click this item, the equipment will automatically recognize upgrading file and upgrade firmware, the corresponding prompt will appear to show upgrade successfully or fail.

3.5 Restore Setting

Restore the machine to default setting that includes the communication setting, the system setting and so on. Selects this item and press OK, the prompt information “Are you sure to execute current operation?” appear on the equipment, Press the OK/ key to restore the default setting, press ESC key to give up this operation.

Note: to restores the setting cannot erase the personnel information and the attendance record in the equipment.

3.6 Automatically test

The equipment provides with the automatic test function to test each module in the fingerprint machine. The function helps the operator firstly check the module, if the machine has some problem. Include TFT screen, voice prompt, clock, keyboard, and fingerprint sensor test. Choose the option to test.



Scroll the ▲/▼ key to select the item that needs to be tested,

press the "OK" key to start the testing

3.6.1 Test TFT screen

Equipment provides auto-test to check the TFT screen demonstration effect. Through when the screen displays in color, entire white, entire black, you can inspect each place of the screen at this time, to check whether the TFT screen demonstrates normally.

Press “OK” to continue to test while the test process, press ESC key to exit from this test.



3.6.2 Test pronunciations

The equipment offer auto-test effect of the voice prompt, through playing voice file in the equipment, to check whether the voice file is completed and the pronunciation effect is in good or not

Press  / “OK” (F7) to continue playing voice while the test process, press “ESC” (F8) key to exit from this test.

3.6.3 Test keyboards

The equipment carries on the automatic detection to each keyboard, to test whether each key of keyboard is normally used. In the keyboard test window, stochastically press any key of the keyboard (except the "OK" and "ESC" F8 key), check whether the key you

press accords with the display on the screen. The key you press display in garnet  color, otherwise the key  in gray black. Press “OK”、 “ESC” (F8) key to exit from this test



3.6.4 Test fingerprint Sensor

The auto-test fingerprint sensor tells user whether the sensor is in normal, through the test you can examine the picture resolution of the fingerprint, to whether the fingerprint picture is clear, and the screen will real-time show fingerprint picture that is captured from the finger while you are placing the fingerprint sensor window.

Press “OK”、 “ESC” (F8) key to exit from this test.

3.6.5 Real-time clocks

The equipment provides function to test the clock, through stopwatch test you will get result that whether the clock is in normal operation or not.

Press the  / “OK” key to start to time, press the  / “OK” key again to stop it, to check whether the equipment time is in accuracy. Press “OK”、 “ESC” (F8) key to exit from this test.

4 Communication setting

If when the data is transferred between the equipment and PC, it is necessary to set the equipment communication parameter according to the transmission cable. When the equipment and the machine are in the communication, the "in the work... .." Message will be displayed on the equipment, Please Do not operate the equipment while the test is running.

Note: please inspect the setting here before the machines communicate with the computer, the parameter must be consistent with the one on the communication option in the software.

To find sitting on the fingerprint machine if you are using Ethernet communication, following sitting:

Machine IP address: Default IP is 192.168.1.201, you must change it; Do not set IP as same as the IP of PC that the fingerprint machine connect with.

Subnet mask: Default mask 255.255.255.0, you must change it.

Gateway address: the Default gateway address is 0.0.0.0, if the equipment and PC is not in the identical network segment, set up the gateway address firstly.

Network speed: The network run speed, there are three kinds of options, automatic adoption, 10M, the 100M. Set network speed according to your equipment that is plugged into a locate area network using Ethernet cable.

To find sitting on the fingerprint machine if you are using serial port (RS232/RS485) to communicate between the equipment and PC, configure the following parameter:

Baud rate: the rate at which fingerprint machine communicate with the PC , there are five kinds of options 9600, 19,200, 38,400, 57,600, 1.15200 bit/sec, the high speed communication is quick, we recommend that high speed apply to the RS232communication ; The low speed communication is stable, it is better the low speed apply to theRS485 communication;

RS232: Whether using RS232 communication or not, if the RS232 will be used, then this choice is "Yes";

RS485: Whether using RS485 communication or not, if the RS485 will be used, then this choice is "Yes"

It is necessary to set the serial number before the PC communicates with the fingerprint machine over the RS232/RS485 cable.

Serial number: The serial number of the fingerprint machine, which scope is from 1 to 254, if when using the RS232/RS485 communication, be sure to input this serial number in the software communication interface firstly.

In order to keep up the security of the time & attendance record data, here you may set up the connection password, unless input this connection password in the PC machine software, and fingerprint machine is unable to interconnect to read the data when the fingerprint machine connect to PC successfully.

Connection password: The system default password is 0(namely

the password does not exist), it is allowed to set it as other values, after setting up, be sure to input this password before the software communicate with the equipment , otherwise you will fail to create connection between the fingerprint machine and PC software. The connection password length is 1 ~ 6.

Instruction



Scroll the ▲/▼、◀/▶key to shift the cursor on the item you need set, scroll the ◀/▶key again to shift the value which you choose. After setting up, directly press **Enter** / “OK” (F7) key to save this setting and return to preceding interface, press the “ESC”(F8) key to cancel and return to preceding interface.

5 User profile

User Profile settings can be set up according to their personal preferences show some style and operation method.



5.1 User Customize

According to their personal preferences, users can set up the initial interface style.

the times of retrying 1:1 verification or password: users go on 1:1 verification or password, who may forget the right registered finger or improperly press fingers. The setting provides user with convenience, and reduces to repeat keys, makes the user to retry the verification after failed to verify within the limited times.

Clock options: When the user is going on the verification operation, regardless it is success or failure, the Clock pattern will display you choose on the screen after verifying.

Public Photo: according to the actual demand, users can upload some public photographs to be displayed on the screen.

1) Photo cyclical interval : how long the interval to shift Photo Display (Scope for 3 to 999 seconds)

2) Duration of the clock showed that after the user is verified how long the clock pictures show. After a show duration, the initial public photos will be displayed on the interface. (Scope 0 ~ 999 seconds, 0 clock that has been shown.)

Note: In the ready working state, the option to the flash player is selected as "yes", after the verification completed, the publicity photos will not be displayed, but the flash will be played.

Timing Sleep: When the equipment was not operating in the state to set up a regular sleep time after the equipment will enter a dormant state. Pressing any button or touch fingers that can awake up the equipment.

Screen brightness adjustments: adjust TFT screen brightness.

Fingerprint Image Display: whether register or match the fingerprint image will be displayed on the screen. There are four options: register and match, only match or register not to display.

Player flash: When the equipment is in the sleep state, whether the play flash .



Background mode: When the equipment is in the sleep state, There are three kinds of background pattern can to choose: First, publicity photos; Second, the background music; Third, flash animation player.

Camera mode: When staff attendance, whether capture operation and display the current snapshot picture. Select "Yes" snapshot, selected as the "no" does not capture.

Note: If the duration of the clock display is set to 0, in ready working state the machine plays full-screen flash; if set to other values, it plays the small screen flash in ready working state.

Instruction



Scroll the  key to choose the box you need input the value with small keyboard, after finishing the setting, please directly press OK or  (F7) key to save this item and return to preceding interface, or press the ESC (F8) key to give up operation and return to interface.

5.2 Video Setting

The built-in camera equipment parameter settings, the camera will have the best performance.

Brightness: Adjustment the brightness of camera capture photo.

Contrast: Adjustment the contrast of camera capture photo.

Picture quality: Setting up quality of the saved picture .

Environment: Setting up the filming environment in which to take effect as the best.

Restore Default: the parameters of the above-mentioned parameters restored to the default values.



Scroll ▲ / ▼ key switching options input box with the small

keyboard and input appropriate number keys to adjust the value of the camera , or press the button will restore the default parameters and restore to the default state. After appropriate adjustments by (F7) or "OK" Save settings, press the "return" from set.

Note: the setting is just available to the unit which has camera.

5.3 Screen Calibration

If the touch screen is not sensitive enough to induce the touch, the screen induction calibration can be adjusted in the menu.

5.4 Bell Setting

Ringing bell to notice people to work is a widely measure in many companies. In tradition, there are two measure to do it by man or with the help of electronic tool. In order to get an economic and convenient management, the time bell function is available in the fingerprint machine. With the schedule bell function, the fingerprint machine will automatically make bell sound during a certain time which is set in advance; when the certain time ends, the bell will automatically stop sounding.

Instruction:

Alarm	Hour	Tone	State
Alarm 1	12:00	alarm01.wav	19
Alarm 2	00:00	alarm02.wav	
Alarm 3	00:00	alarm03.wav	
Alarm 4	00:00	alarm04.wav	
Alarm 5	00:00	alarm05.wav	
Alarm 6	00:00	alarm06.wav	
Alarm 7	00:00	alarm07.wav	
Alarm 8	00:00	alarm08.wav	
Alarm 9	00:00	alarm09.wav	
Alarm 10	00:00	alarm10.wav	



Scroll ▲/▼ key to view the bell setting at line by line.

Scroll F5/F7key to view the bell setting in page by page.

Press "⏏/⏏" key to begin/end the selected bell.

Press "OK"/F5 to choose one of the bell setting, and enter the edition bell.

Bell time: time out, bell rings;

Sound choice: different sound in different time.

Volumes adjust: Bell sound volume.

Number of times: times of bell ringing

Bell state: start this bell or not.



Scroll the▲/▼key to shift the cursor to input box, set up the value with the numeric keyboard input. After the setting, directly press OK or the  /“OK”(F7) key to save the settings and return to preceding interface, press the ESC(F8) key to give up.



5.5 The Definitions of Keyboards

5.5.1 State Key Definition

Customize the attendance state key in the equipment, after pressing the corresponding state key again, the attendance log is recorded in

this state key.

When press any state key on initial interface, the attendance state corresponding to the state key will appear under the leftside of the screen, that is convenient for users to check.

Instruction



Scroll the ▲/▼ key to shift option box, Scroll ◀/▶ key to change the setting. After the setting completed, please press **⌘/↵** /“OK” (F7) to save this configuration, press the ESC (F8) key to give up the operation and return to the interface.

Note: If some state keys would not be used, then set the state keys as invalid. **◀▶⌘/↵**

5.5.1 Using State Key

On main interface, press “F5”, the corresponding state key will appear at the left bottom of the screen.



Then user can do the verification by fingerprint or password, the equipment will keep the attendance record at the corresponding state

6 Inquiry Record

If the fingerprint machine successfully record the staff time & attendance, the record will be saved in. the inquiry record function has been designed in simple and manner to help user find his/her attendance logs he/she need quickly and easily. this machine offer the inquiry function. Different ways are available in unit to check the users' logs.

Enter the attendance inquiry menu, the first box is used for inputting condition. Enter the ID No. and the Data:

The screenshot shows the attendance inquiry menu with the following fields and values:

ID NO	All				
Name					
Start	06	M	25	D	0 H
End	08	M	28	D	24 H

- 1) All AC. No, that inquiries all staff.
 - 2) Import a certain AC.No, only for the certain staff attendance record.
- Press  / "OK" (F7) key to inquiry, the records that meet you

input condition will be displayed on the screen

Date	ID/NO	Name	Allog			
08/28	1	Jack	7:34	12:10	13:25	17:48
08/29	1	Jack	7:28	12:05	13:21	17:38
08/30	1	Jack	7:50	12:20	13:29	17:25

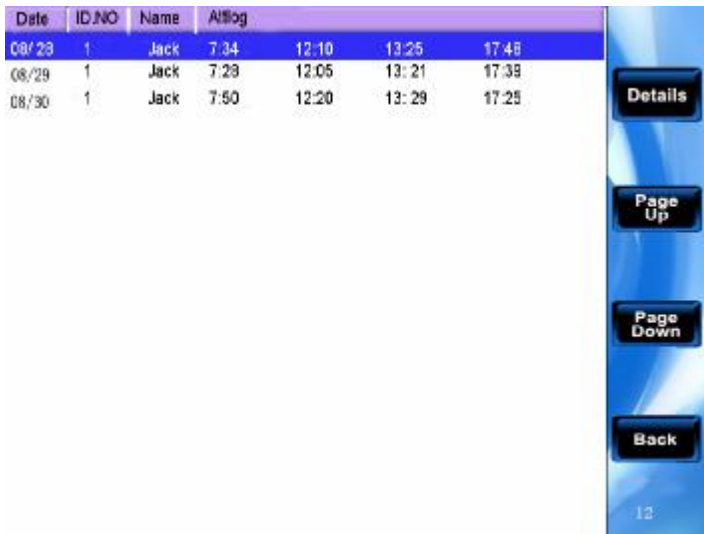

The screenshot shows a vertical interface with a table of attendance records on the left and a vertical column of buttons on the right. The table has columns for Date, ID/NO, Name, and Allog. The first row is highlighted in blue. The buttons on the right are labeled 'Details', 'Page Up', 'Page Down', and 'Back'. At the bottom of the interface, the number '12' is displayed.

Scroll ▲ / ▼ key, move the cursor on the line you want, press  /“OK” (F5) to enter attendance record Details view.

For example, on August 28 on the 1st staff, Press Details to check.

ID NO	Name	Alllogs	Ver/ied	State
1	Simon	08/28 08:25	FP	Check-In
1	Simon	08/28 12:04	FP	Check-In
1	Simon	08/28 13:20	FP	CHEck-In
1	Simon	08/28 18:12	Pwd	Check-out



The image shows a vertical sidebar on the right side of the table. It contains three black buttons with white text: 'Page Up', 'Page Down', and 'Back'. Below these buttons, the number '01' is visible, likely indicating the current page number.

If the records fulfill the first page, press F6/F7 to turn on next page..
Press the "ESC" (F8) to return to the previous interface.

7 USB Flash Disk Management

Using USB flash disk is able to download user's information, fingerprint templates, attendance logs, and upload it into the tracking software for processing. Meanwhile, user's information and fingerprint templates are able to upload into other fingerprint equipments. When the font of button display in blue color, means that the device does not support this function, this function is not available.



Instruction

7.1 Upload User data

Upload user's information and fingerprint templates which have been saved in the USB flash disk into the equipment.

Instruction

Plug the USB flash disk into the USB slot of the fingerprint machine, scroll "▲/▼" key to choose the user data that you want to upload, press the OK key. The two files, user.dat (user information) and template.dat (fingerprint template), will be uploaded to the machine. If the two files in the USB flash disk are not complete, the prompt "failed to deal data, check your U flash disk".

7.2 Download User's Data

Save all user's information and fingerprint templates from the equipment into the USB flash disk.

Instruction

Operation is similar with the attendance data.

Plug the USB flash disk into the USB slot of the fingerprint machine, Scroll the "▲/▼" key to choose user data you want to download, if download successfully , the files user.dat (user information) and template.dat (fingerprint template) will be viewed availably

7.3 Upload the Customized Picture

Upload the file with JPG picture format which front name as "ad_" in the USB flash disk into the equipment, after these pictures have been transfer to the equipment, it will display in the initial window. (Picture specification, please see appendix 4)

Instruction



Plug the USB flash disk in the USB slot of the fingerprint machine, scroll "▲/▼" key to preview the picture in the USB flash disk then press the OK key to choose the picture you want to upload. If the prompt "upload successfully" is displayed on the equipment, the file will automatically jumps to the next picture. After completing uploading the pictures, press ESC(F8) key to exit.

7.4 Download Attendance Datum

Save all attendance datum from the equipment into the USB flash disk.

Instruction

- 1) Plug the USB flash disk into the USB slot of the fingerprint machine through the mini USB cable.
- 2) Scroll "▲/▼" to select the "Download Attlog".
- 3) Press "ok" to go on downloading data, the equipment prompt "is downloading , please waits... .." until the equipment prompt "download attendance data successfully".
- 4) Press "OK" key to exit from this interface. Take out U flash disk. The files X_attlog.dat (attendance log), X_oplog.dat (management log), and X_user will be saved in the USB flash disk(X is a symbol of machine No.)

7.5 Users Upload Photos

Upload the JPG picture file which is named by AC.NO in the U Flash disk. After upload, while the staff finish verification, the staff's photo will show in the display

Insert the U flash disk into the USB slot of the fingerprint machine, Scroll "▲ / ▼" key to preview the qualified pictures in the U flash disk, find the favor pictures , press "OK" button to upload. When

the equipment prompt successful uploading, it will automatically turn to next picture. Complete uploading, press the "ESC" to exit.

7.6 Download User's Photos

To save staff photo which is taken by the equipment into U flash disk.

Instructions

Insert U flash disk into the USB slot of the fingerprint machine, scroll "▲ / ▼" button to select user's pictures. If the user picture was downloaded successfully, it will be found in disk.

7.7 Upload Short Message

Upload the short message from the U flash disk into equipment.

Instructions

Insert the U flash disk into the USB slot of the fingerprint machine, Scroll "▲ / ▼" button to select user upload datum. Press "OK" button, the two files, udata.dat. and sms.dat, will be uploaded to the machine.

7.8 Download Short Message

Short Message in the equipment can be saved in the U flash disk .

Instructions

Insert the U flash disk into the USB slot of the fingerprint machine. Scroll "▲ / ▼" button to select users download data. Press "OK" button, the two file, udata.dat. and sms.dat in the machine will be downloaded to the disk.

7.9 Upload Flash

Before you upload the Flash file into the equipment, please contact our technical support. Our support will make it to meet your demand, to support you upload the documents through U flash disk.

8 Information Release

The short message is similar to bulletin and notice. With the function, operator is able to schedule and edit the content of the short message that will be displayed on the screen. The short message is consisted of public short message and individual short message. If the public short message is configured, the icon 📁 will display on the information bar of the window in the assigned time. The default key is "#" key (customerized keyboard) which is available to the short message content. If the individual short message is setted, the system will show the short message to the staff after the staff verifying successfully.

Instruction



Scroll ▲ / ▼ keys to read his party Short Message.

Press F6/F7 keys by reading a chapter in the short message.

Press "OK" / F1 to view the selected Short Message Details.

Press F2 to view new short message.

Press F3 to edit short message.

Press F4 to delete Short Message

8.1 Establish Short Message

1) Add short message

Press F2 key to add short message in the pop-up menu..

Start time: the time the short message starts.

Show period: within the show period the short message will be displayed; after the period, the short message will stop.

Message type: Individual: only for individual

Public: All people are able to see.

Initialization: the initial short message, that means no individual and public short message.

Instruction



When the cursor locate in the text box, press “*”key to open the T9 input method, input the content of the short message, scroll the ▲/▼ key to switch the input box, scroll ◀/▶ to change setting or keyboard and input the value with the small numeric keyboard.

(1) If the type of individual short message is your choice, the distributing button is available; here the individual short message will be distributed to the staff



Scroll ▲/▼key to search personnel line by line .

Press "OK" key to choose the personnel, then short message will be released to this staff.

Press **M/←**/F7/F8 key to save your choice and exit.

Note: Before finishing the steps, please do not exit, or the setting will not work and turn to the initialization.

(2) while in public short message or initialization, the distributing button will not work. After completing the setting, press **M/←**/F7/F8 key to save it and return to the short message list.

2) Edit short message

Press **F3** key to edit short message.

The operation to edit the short message is same with one to add the short message.

3) Delete Short Message

Press **F4** key to delete the short message.

Device will prompt “Are you sure to delete this short message? :
Press “OK” to confirm the deletion, press “ESC” to give up the operation

8.2 View Staff Short Message

1) Check the public short message

While the public short message is working, the main interface show the picture and the content of the message, the interval display time will turn around with advertising picture, if there are many short messages, please scroll ▲/▼ keys to read



2) Examine individual short message

If the user who has the message verified successfully, the short message

content will be displayed.

The duration of the message display is 30 seconds, after the message, the user verification begins working.

9. Systems Information

From system information icon, you are able to know the information about the device, like Free volume and Engaged templates.

9.1 Equipment Information

In the equipment information, there are the equipment name, serial number and firmware version.

9.2 Logs Capacity

Through the log capacity you can check the number of users, managers, registered password in this machine; the machine provides the vivid graphic of fingerprint capacity, attendance logs capacity in order to show the free capacity and the used capacity of each item.



Appendix 1

Getting Familiar with Keyboard

The equipment keyboard has different usage in different interface, for details please see the next table.

Key	Detailed solution
numeric keyboard	1, 0 ~ 9, is used in to input the staff to number, numeral and password so on.
Function Key	1. Main menu , that is used as attendance state key. 2. The shortcut key, if there is operation item in the screen ,and relate the button position
▲	1、 Upward . 2、 Upward/forward switch option
▼	1、 Downward. 2、 Downward/Backward switch option.
▶	1、 Revision current value.
◀	1、 Revision current value
⊙	1、 Shut down key. Keep press the key for 3 seconds in the initial interface to shut down the unit.
←	1、 Backspaces key. While inputting wrong AC.NO, password, system setting value, press the key to delete the value.

	menu key, confirms ESC key
OK	Confirm and save
ESC	1、 Cancel operation and return to the preceding of menus 2、 Press ESC key to close T9 input method
*	1.start the T9 input method
#	1.The backspaces key in T9 input method

Appendix 2

T9 Input Method

T9 input method is a intelligent input method; it is famous for highly effective inputting the character. The equipment fully supports T9 with Chinese, English and symbol input. There are three or four English letters on 0 ~ 9 numeric keyboards of the machine, for example the numeric keyboard 1 has the A, B, C three letters, only input key where this letter locate for the T9 Chinese, the program will automatically spell Pinyin. Then press the numeric key to choose Pinyin to input the Chinese character. T9 English also comply with the letter arrangement of English word to input, only press key, then the program automatically display this key expressing all letters, press the numeric key to select the letter. T9 input method can support inputting some marks. User is able to input the name and the short message content by using T9 input method key.

T9 input method key distribution and its function as blow:

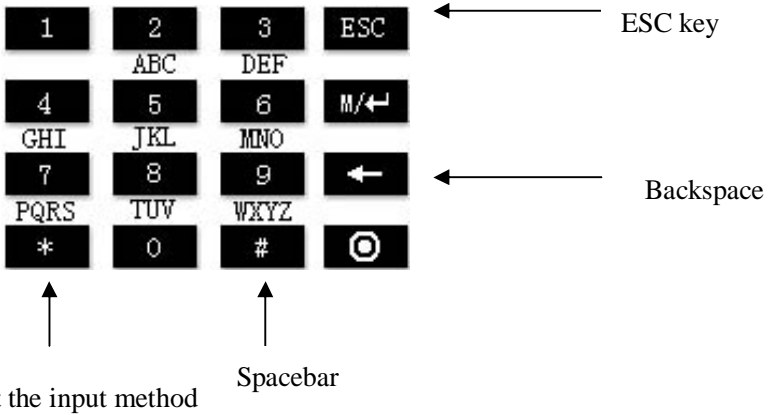

▲/▼/◀/▶: Turn page key

OK: Choose letter

Take an example for the T9 English input: Input "Arabia " press the * numeric key to enter the T9 input method.T9

Registered users

Registered users:
Including the work code input (support up to 22 digits),
Name (press the F1 key to open TS input method,
press ESC key to close TS input method); Register new
fingerprint, backup fingerprint (a register for a maximum
of 0), Register password; Assign user privileges
(administrator, ordinary user).

ID.NO

Name

FP FP Num :0

PWD

ALTH

[ENGLISH]
De It Zh Sp Ar Kc

ZKSoftware
The Advanced Biometric Technology

Done

Back

Press OK



Scroll ◀▶ key or input the letter you select.

Press 4

If the operation must be carry on, please use the above method to do it again. After the input is completed, press the ESC key to exit

Appendix 3

Quickly Inquire Staff Attendance Logs

In order to help ordinary user to view his/her Time & Attendance record at same time, whether forgetting clock-in or occurring error, should well inform the manager that the attendance record is in abnormal.

Instruction

After the machine verify fingerprint or the password successfully in 10 seconds, then pressed “OK”/  key to be able to show this staff all records at same time.

For example: the staff, who’s AC.NO is 1, match the fingerprint successfully, then the press “OK”/  key, you will be able to view his /her Time & Attendance record at the same time.

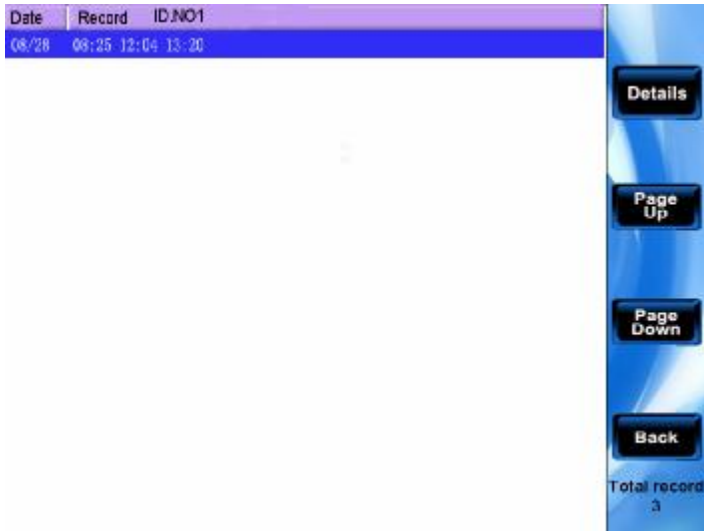

Scroll the ▲/▼ key to browse the Time & Attendance record line by line

Press F6/F7 key page by page to browse the Time & attendance record;

Press “OK” or  key show detailed inquiry.

Press ESC/F8 key to return the initial interface.

Appendix 4

The Rule about the Advertising Pictures

Custom Photo specifications:

1. Photo format is JPG format to the other formats Do not support the format of photographs must be "ad_" as its head. For example ad_12.jpg is legitimate.
3. After photo is uploaded , the file name is not changed, following the replacement of the second pictures. You can upload pictures with the names of the coverage.
4. The size of each picture can not be more than 200 K, otherwise they can not be uploaded.
5. Picture resolution is 800 * 555 high-width, preferably not more than or less than the resolution
6. Only maximum photos: 16

Users upload photos:

Firstly upload pictures to equipment with U flash disk. After uploading and machine verifies fingerprints, photo will be able to show at same time .

1. User photos must be JPG format, the file name, must be named. For example: the 154 users of the corresponding photos is 154. Jpg.
2. Because limit by this version, the names of user photos only no more than eight digital, such as: 12345678. Jpg is legal. On this issue, we are deeply sorry about the inconvenience caused to you and we will be fix this problem in next version.
3. Before uploading , the file folder that is called as “photo” in the U

flash disk must be established, all users need upload photos within this folder.

4. while uploading, insert U flash disk into USB slot of the fingerprint machines, scroll the "▲ / ▼" key to preview qualified photographs in U flash disk, select the photos you need to upload. If you need to upload all photos in the U flash disk, select "Upload user data."

5. When downloading, will be automatically built a folder called photo, users can download all the pictures within this folder.

6. If you need to download all photographs in the machines one time, select "Download user data."

Appendix 5 battery specifications and Notice

Maximum output voltage

DC15.0V

Output voltage

DC12.0V

Rechargeable power supply specifications

DC12V - 1.5A

Cycle life

The number of charge-discharge cycle ≥ 500

Charging time (H)

3.5 ± 0.5

Discharge time (H)

3.5 ± 0.5

Storage Environment

Temperature: 15 ° C to 25 ° C

Relative Humidity: 45% -75%

Battery specifications

Notice

- 1, when batteries is in use, please Do not plug and pull power supplies too frequent (2-3 seconds), maybe cause failed to recharge;
- 2, Do not use the battery in a very hot environment, , such as direct sunlight. Otherwise, the battery will overheat, might fire (fire), it will affect the performance of the battery and short the life s of batteries used;

3, the battery has vent fluid, electrolysis also caused eye, skin or clothing, immediately wash with water flow, or seek immediate medical assistance;

4, please correct for battery installation and dismantling, otherwise it will affect the performance and battery life.

Caution:

There are dangers of battery exploding, leak, fever, fire, break if you don't read the notice carefully.

- ! Do not put the battery into water or let it to get wet.

- ! Do not use and store battery near heat-generating device (such as fire or heater).

- ! Please use original charger only.

- ! Do not inverse polarity connection.

- ! Do not throw batteries into fire or hot battery. Do not use wire or other metal short the positive and negative terminal, donot transit or storage it with necklace, barrette and other metal object.

- ! Do not break battery cause short-circuit battery

- ! Dropping a battery may cause a strong physical shock that may damage the performance of the battery